

FLEXSHADE® Quad™

- Features:**
- ✘ Acrylic or Tedlar® PVC/Polyester Membrane.
 - ✘ Hot Zinc & Powder Coated Steelwork.
(Alternative Stainless Steel Support Frame)
 - ✘ Stainless Steel Cables & Fittings.
 - ✘ Minimal Footings for Area Covered.
 - ✘ Designed to AS1170 Wind Code and to comply with other Codes worldwide.

Quad™ Series

Square Module Quad™

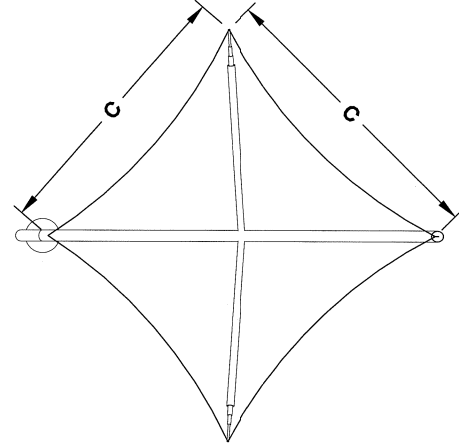
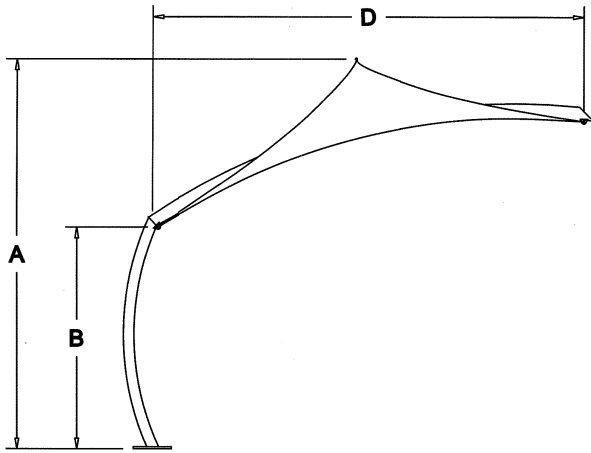

TYPE	*A	*B	*C	*D	WEIGHT
Quad 'QD.2.0M'	3425	2100	2000	2830	85 kg
Quad 'QD.3.0M'	3630	2100	3000	4020	135 kg
Quad 'QD.4.0M'	4200	2100	4000	5607	185 kg

Quad™ Links

Flexshade® Quad™ modules can be connected to provide weatherproof cover.

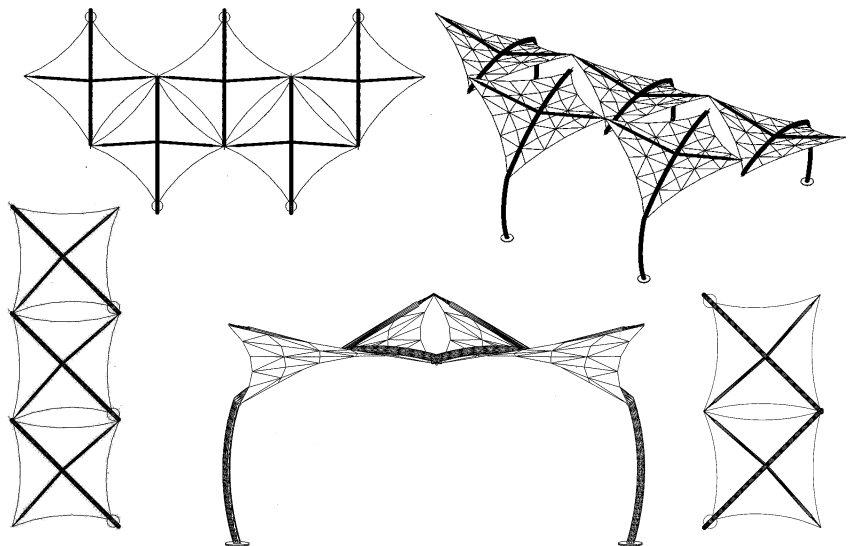

Flexshade®Quad™ can be supplied with membrane on top or below the steel.



An Activity of **TENSION SPAN STRUCTURES PTY LTD** ABN 20 050 400 836
 62 Commercial Road, Fortitude Valley, Queensland, Australia 4006
 Ph: (07) 3854 1900 Intl Ph: +61 7 3854 1900 Fax: (07) 3252 1252
 Email: sales@flexshade.com Web: www.flexshade.com