

FLEXSHADE® Quad™

- Features:**
- ✘ Acrylic or Tedlar® PVC/Polyester Membrane.
 - ✘ Hot Zinc & Powder Coated Steelwork.
(Alternative Stainless Steel Support Frame)
 - ✘ Stainless Steel Cables & Fittings.
 - ✘ Minimal Footings for Area Covered.
 - ✘ Designed to AS1170 Wind Code and to comply with other Codes worldwide.

Quad™ Series

Square Module Quad™

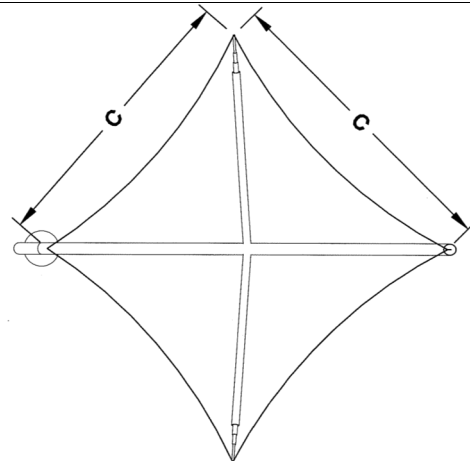
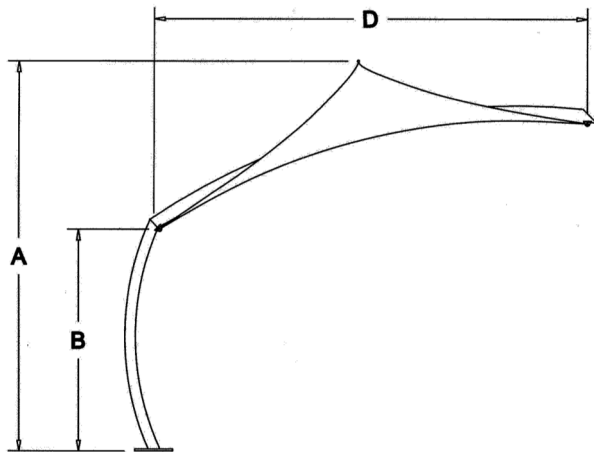

| TYPE | *A | *B | *C | *D | WEIGHT |
|------------------|------|------|------|------|--------|
| Quad 2m x 2m | 3425 | 2100 | 2000 | 2830 | 85 kg |
| Quad 2.5m x 2.5m | 3527 | 2100 | 2500 | 3425 | 110kg |
| Quad 3m x 3m | 3630 | 2100 | 3000 | 4020 | 135 kg |

Quad™ Links

Flexshade® Quad™ modules can be connected to provide weatherproof cover.

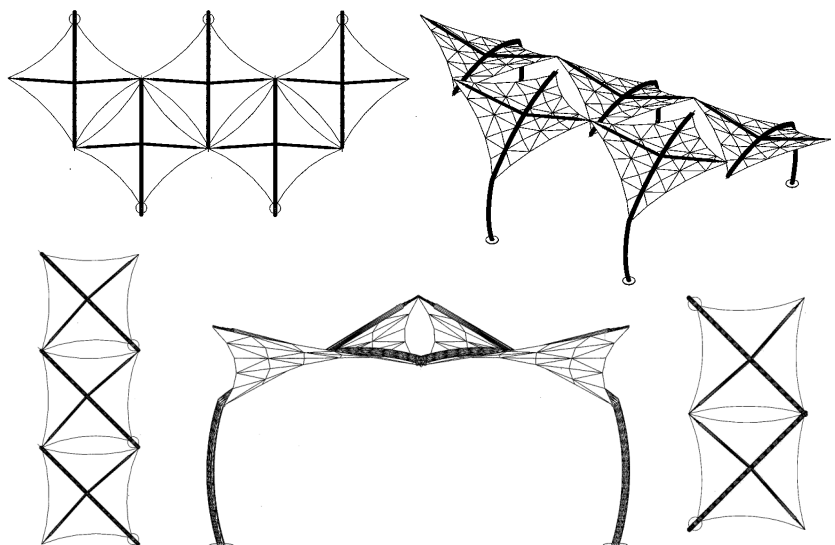

Flexshade® Quad™ can be designed to suit specific customer requirements for height and plan dimension.



An Activity of **TENSION SPAN STRUCTURES PTY LTD** ABN 20 050 400 836
 62 Commercial Road, Fortitude Valley, Queensland, Australia 4006
 Ph: (07) 3854 1900 Intl Ph: +61 7 3854 1900 Fax: (07) 3252 1252
 Email: sales@flexshade.com Web: www.flexshade.com